



CATALOG OF REPLACEMENT PARTS



DISHWASHER

AM15	ML-130038
AM15T	ML-130039
AM15F	ML-130045

Table of Contents

5	CONTROLS
7	CONTROL BOX (ELECTRIC HEAT)
9	CONTROL BOX (GAS HEAT)
11	MOTOR AND PUMP
13	UPPER WASH ARM
15	LOWER WASH ARM
17	INSIDE PIPING AND OUTSIDE RINSE PIPING (W/O BOOSTER)
19	INSIDE PIPING AND OUTSIDE RINSE PIPING (W/BOOSTER)
21	ELECTRIC BOOSTER TANK
23	LOW WATER PROTECTION AND ELECTRIC HEAT
25	DRAIN UNIT
27	DOOR ASSEMBLY (AM15)
29	DOOR ASSEMBLY (AM15T & AM15F)
31	PANELS AND RACK SUPPORT
32	FRONT TRAY (AM15F)
33	GAS HEAT PIPING
35	GAS HEAT COMPONENTS
36	DISH RACKS

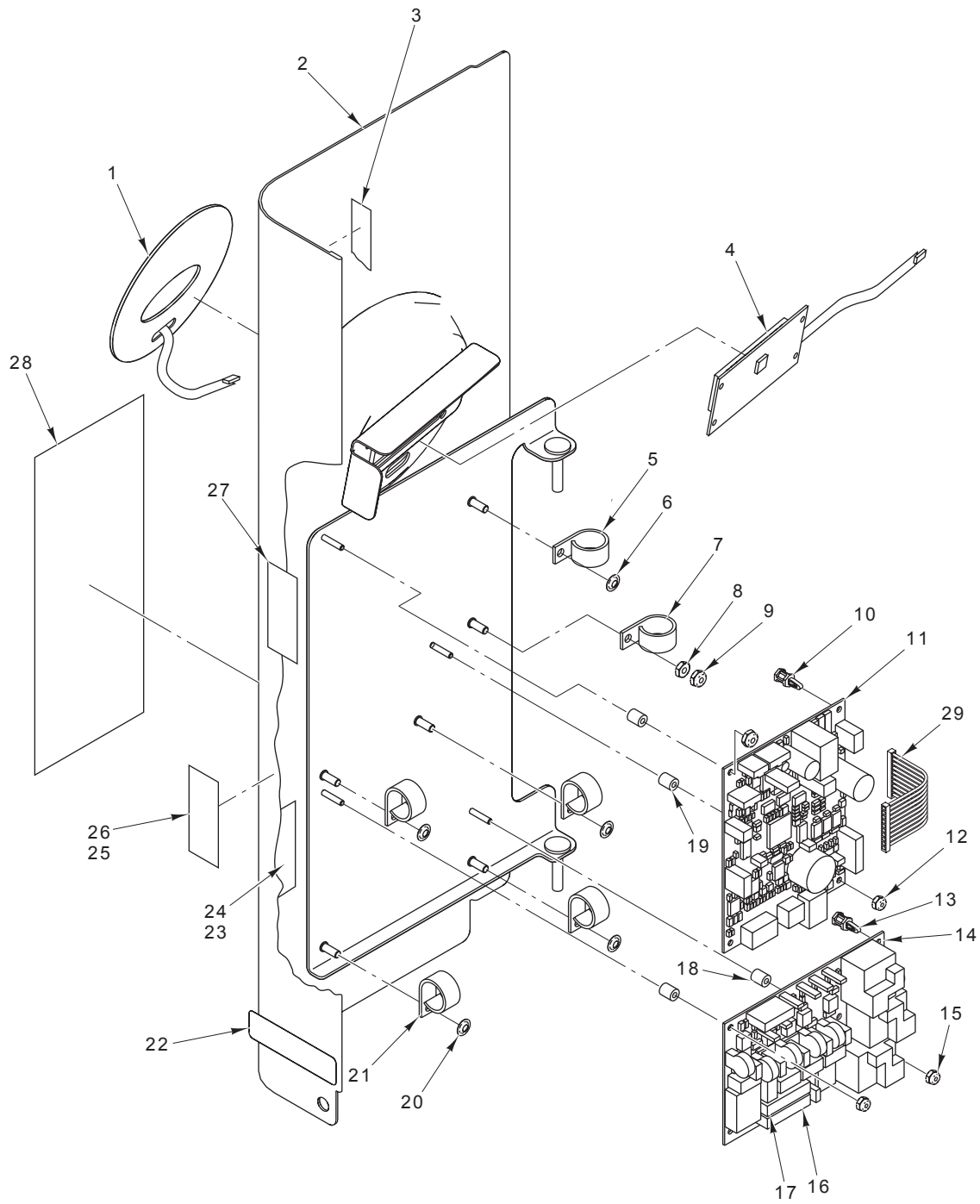

PL-57404

CONTROLS

CONTROLS

ILLUS.	PART NO.	NAME OF PART	AMT.
PL-57404			
1	00-893113	Switch – Membrane Keypad.....	1
2	-	Bezel – Display Weldment.....	1
3	00-526454	Tape – Foam	AR
4	00-892458	Module – Display	1
5	00-294677-00003	Clamp – Wire	1
6	NS-047-94	Lock Nut ³ / ₁₆ Washer Type	1
7	00-294677-00003	Clamp – Wire	1
8	NS-011-18	Nut 10-24 Hex	1
9	NS-031-16	Stop Nut 10-24 Hex	1
10	00-892720-00002	Standoff	2
11	00-892932	Board – Control Assy.	1
12	NS-031-50	Stop Nut 6-32 Hex	2
13	00-892720-00002	Standoff	2
14	00-892934-00001	Board – Relay Assy.	1
15	NS-031-50	Stop Nut 6-32 Hex	2
16	FE-022-29	Fuse (250 V., 1.0 Amp.)	1
17	FE-026-30	Fuse (250 V., 0.1 Amp.)	1
18	00-118349-00007	Standoff – Reed Board (Relay Board)	2
19	00-118349-00007	Standoff – Reed Board (Control Board).....	2
20	NS-047-94	Lock Nut ³ / ₁₆ Washer Type	4
21	00-294677-00003	Clamp – Wire	4
22	00-893642	Plate (Patent Numbers).....	1
23	0F-035324	Label – Warning (Fuse) (Electric Heat)	1
24	0F-035373	Label – Warning (Fuse) (Gas Heat)	1
25	00-438131-00060	Label – Warning (W/Electric Booster)	1
26	00-438131-00042	Label – Warning (W/Gas Heat, W/Electric Booster S.P.E.C., or W/O Electric Booster) .	1
27	0F-035331	Label (Error Code)	1
28	00-438131-00175	Label – Instruction	1
29	00-892793-00002	Ribbon Cable Assy.	1
	00-893447	Harness – Sensor Assy.	1
	00-893448	Harness – Relay Board Assy.	1
	00-893125	Cable – Rinse Thermistor	1
	00-893126-00001	Cable – Rinse Valve (Without Electric Booster)	1
	00-893126-00002	Cable – Rinse Valve (With Electric Booster)	1

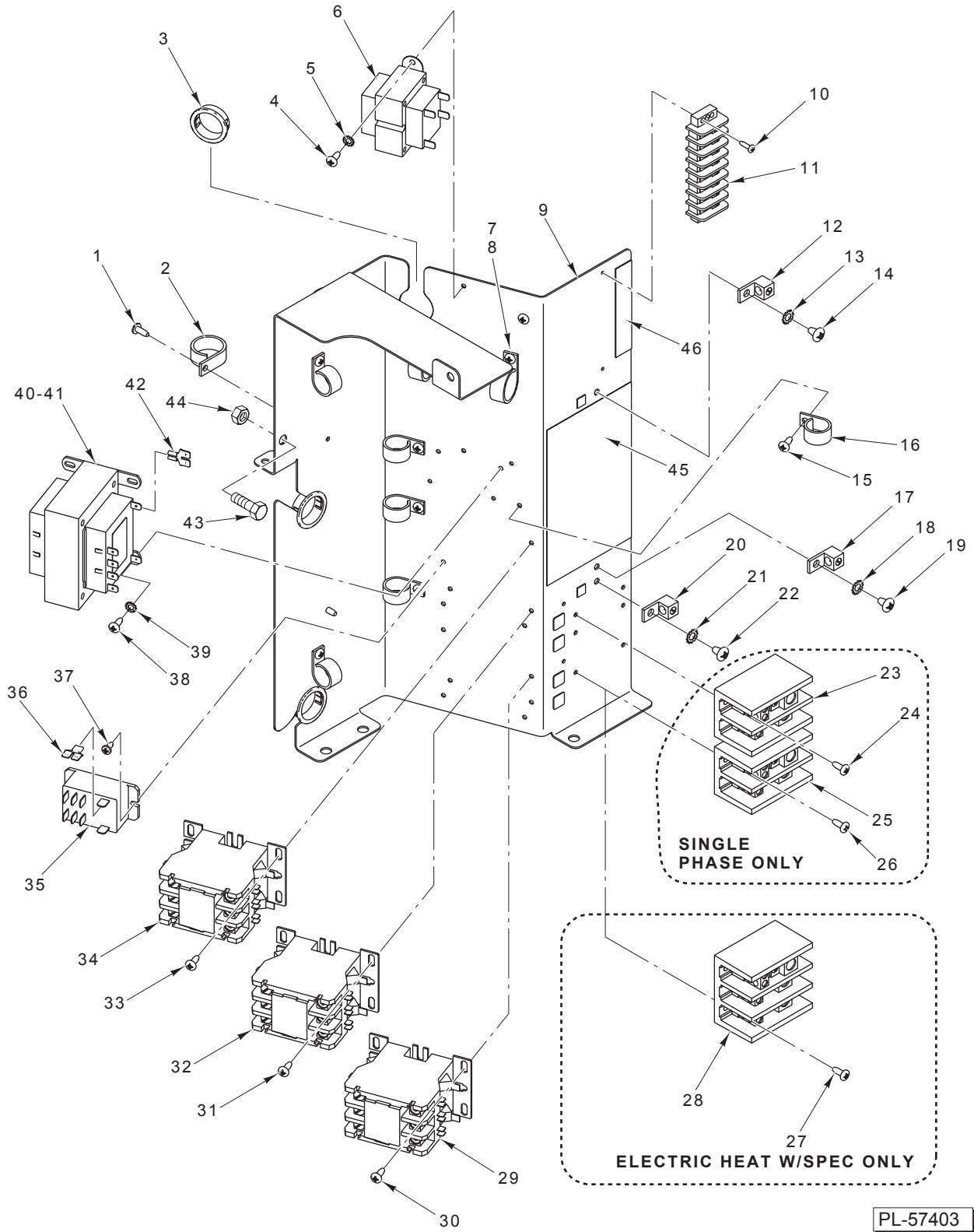

CONTROL BOX (ELECTRIC HEAT)

CONTROL BOX (ELECTRIC HEAT)

ILLUS. PL-57403	PART NO.	NAME OF PART	AMT.
1	SD-008-25	Self-Tapping Screw 10-16 x 1/2 Phil. Pan Hd., Type B	3
2	00-294677-00004	Clamp – Wire	3
3	FE-026-29	Bushing – Snap (Electrical)	3
4	SD-008-25	Self-Tapping Screw 10-16 x 1/2 Phil. Pan Hd., Type B	2
5	WL-014-07	Lockwasher #10 External	1
6	00-294500-00051	Transformer (30 VA, 50/60 Hz.)	1
7	SD-008-25	Self-Tapping Screw 10-16 x 1/2 Phil. Pan Hd., Type B	2
8	00-294677-00004	Clamp – Wire	2
9	00-893651	Box – Control	1
10	SD-019-29	Self-Tapping Screw 6-20 x 1/2 Phil. Pan Hd., Type B	2
11	00-893065	Block – Terminal (Double Row)	1
12	00-118544-00002	Lug – Solderless	1
13	WL-007-15	Lockwasher 1/4 External	1
14	SD-035-77	Self-Tapping Screw 1/4-20 x 3/8 Phil. Pan Hd., Type TT	1
15	SD-008-25	Self-Tapping Screw 10-16 x 1/2 Phil. Pan Hd., Type B	6
16	00-294677-00003	Clamp – Wire	6
17	00-118544-00002	Lug – Solderless (Electric Booster)	1
18	WL-007-15	Lockwasher 1/4 External (Electric Booster)	1
19	SD-035-77	Self-Tapping Screw 1/4-20 x 3/8 Phil. Pan Hd., Type TT (Electric Booster)	1
20	00-118544-00002	Lug – Solderless	1
21	WL-007-15	Lockwasher 1/4 External	1
22	SD-035-77	Self-Tapping Screw 1/4-20 x 3/8 Phil. Pan Hd., Type TT	1
23	00-294325-00022	Block – Terminal (1 Ph.)	1
24	SD-008-25	Self-Tapping Screw 10-16 x 1/2 Phil. Pan Hd., Type B (1 Ph.)	2
25	00-294325-00022	Block – Terminal (Electric Booster) (1 Ph.)	1
26	SD-008-25	Self-Tapping Screw 10-16 x 1/2 Phil. Pan Hd., Type B (Electric Booster) (1 Ph.)	2
27	SD-008-25	Self-Tapping Screw 10-16 x 1/2 Phil. Pan Hd., Type B (Electric Heat W/S.P.E.C.)	4
28	00-119031	Block – Terminal (Electric Heat W/S.P.E.C.)	1
29	00-087713-041-2	Contactora (40 Amp., 3-Pole, 120 V.) (Electric Booster)	1
30	SD-008-25	Self-Tapping Screw 10-16 x 1/2 Phil. Pan Hd., Type B (Electric Booster)	2
31	SD-008-25	Self-Tapping Screw 10-16 x 1/2 Phil. Pan Hd., Type B	2
32	00-087713-108-1	Contactora (25 Amp., 3-Pole)	1
33	SD-008-25	Self-Tapping Screw 10-16 x 1/2 Phil. Pan Hd., Type B	2
34	00-087713-108-1	Contactora (25 Amp., 3-Pole)	1
35	00-087714-046-1	Relay (30 Amp., 2-Pole)	1
36	FE-026-26	Adapter – Electrical	1
37	SD-008-18	Self-Tapping Screw 8-18 x 3/8 Phil. Bndg. Hd., Type B	2
38	SD-008-25	Self-Tapping Screw 10-16 x 1/2 Phil. Pan Hd., Type B	4
39	WL-014-07	Lockwasher #10 External	1
40	00-294500-052-1	Transformer (208/240/480 V., 50/60 Hz.)	1
41	00-294500-052-2	Transformer (380/415 V., 50/60 Hz.)	1
42	FE-026-26	Adapter – Electrical	1
43	SC-041-14	Cap Screw 5/16-18 x 1 1/8 Hex Hd.	4
44	NS-036-19	Stop 5/16-18 Nut Hex	4
45	0F-035369	Label – Rinse Feeder	1
46	0F-035319	Label – Terminal Block	1

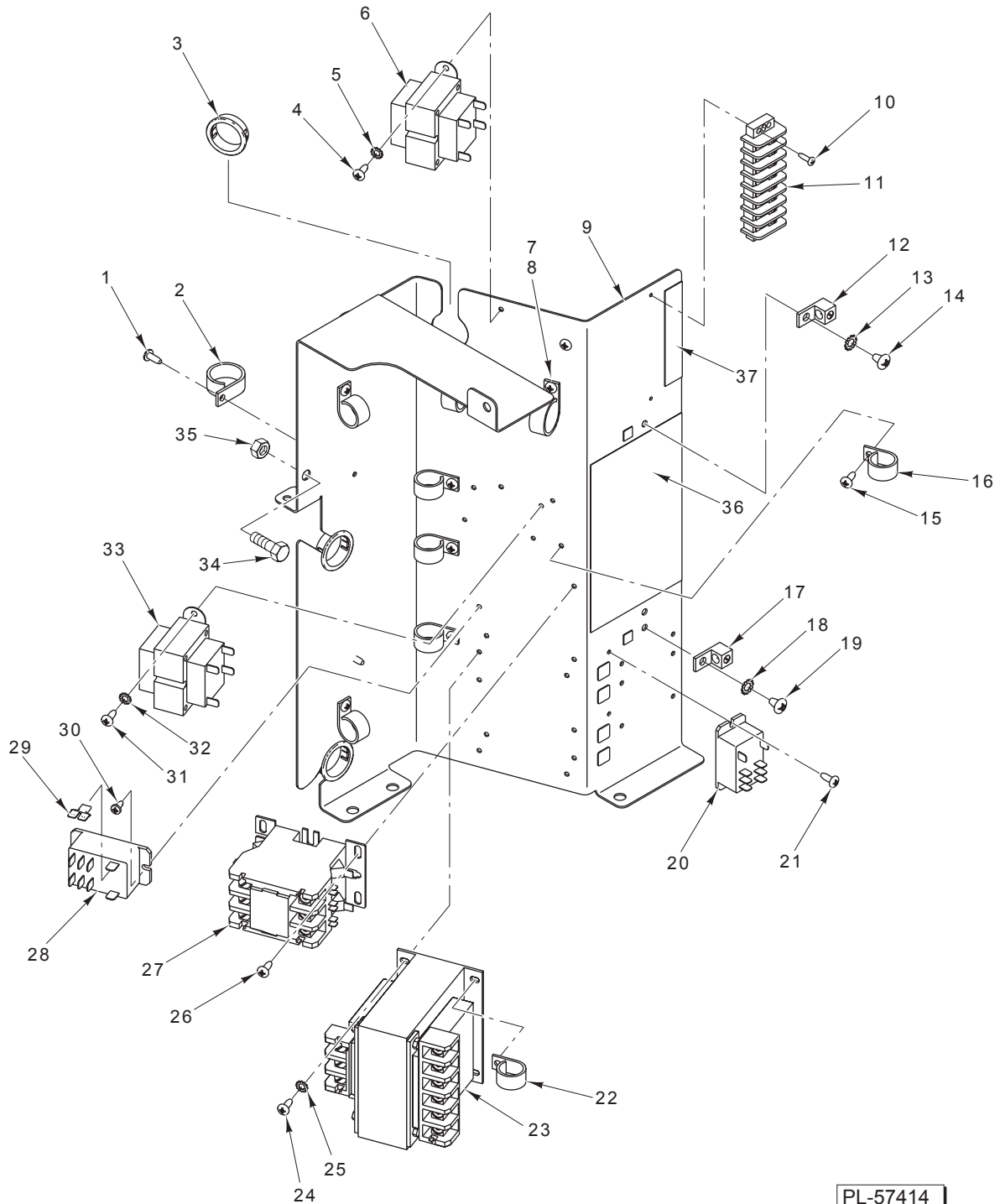

PL-57414

CONTROL BOX (GAS HEAT)

CONTROL BOX (GAS HEAT)

ILLUS. PL-57414	PART NO.	NAME OF PART	AMT.
1	SD-008-25	Self-Tapping Screw 10-16 x 1/2 Phil. Pan Hd., Type B	3
2	00-294677-00004	Clamp – Wire	3
3	FE-026-29	Bushing – Snap (Electrical)	3
4	SD-008-25	Self-Tapping Screw 10-16 x 1/2 Phil. Pan Hd., Type B	2
5	WL-014-07	Lockwasher #10 External	1
6	00-294500-00051	Transformer (30 VA, 50/60 Hz.)	1
7	SD-008-25	Self-Tapping Screw 10-16 x 1/2 Phil. Pan Hd., Type B	2
8	00-294677-00004	Clamp – Wire	2
9	00-893651	Box – Control	1
10	SD-019-29	Self-Tapping Screw 6-20 x 1/2 Phil. Pan Hd., Type B	2
11	00-893065	Block – Terminal (Double Row)	1
12	00-118544-00002	Lug – Solderless	1
13	WL-007-15	Lockwasher 1/4 External	1
14	SD-035-77	Self-Tapping Screw 1/4-20 x 3/8 Phil. Pan Hd., Type TT	1
15	SD-008-25	Self-Tapping Screw 10-16 x 1/2 Phil. Pan Hd., Type B	6
16	00-294677-00003	Clamp – Wire	6
17	00-118544-00002	Lug – Solderless	1
18	WL-007-15	Lockwasher 1/4 External	1
19	SD-035-77	Self-Tapping Screw 1/4-20 x 3/8 Phil. Pan Hd., Type TT	1
20	00-087714-046-1	Relay (30 Amp., 2-Pole)	1
21	SD-008-18	Self-Tapping Screw 8-18 x 3/8 Phil. Bndg. Hd., Type B	2
22	00-294677-00003	Clamp – Wire	2
23	00-294500-046-2	Transformer (300 VA, 50/60 Hz.)	1
24	SD-008-25	Self-Tapping Screw 10-16 x 1/2 Phil. Pan Hd., Type B	4
25	WL-014-07	Lockwasher #10 External	1
26	SD-008-25	Self-Tapping Screw 10-16 x 1/2 Phil. Pan Hd., Type B	2
27	00-087713-108-1	Contactactor (25 Amp., 3-Pole)	1
28	00-087714-046-1	Relay (30 Amp., 2-Pole)	1
29	FE-026-26	Adapter – Electrical	1
30	SD-008-18	Self-Tapping Screw 8-18 x 3/8 Phil. Bndg. Hd., Type B	2
31	SD-008-25	Self-Tapping Screw 10-16 x 1/2 Phil. Pan Hd., Type B	2
32	WL-014-07	Lockwasher #10 External	1
33	00-294500-040-1	Transformer (30 VA, 50/60 Hz.)	1
34	SC-041-14	Cap Screw 5/16-18 x 1 1/8 Hex Hd.	4
35	NS-036-19	Stop 5/16-18 Nut Hex	4
36	0F-035372	Label – Service Ampacity	1
37	0F-035319	Label – Terminal Block	1
	00-893874	Harness – Gas Heat	1

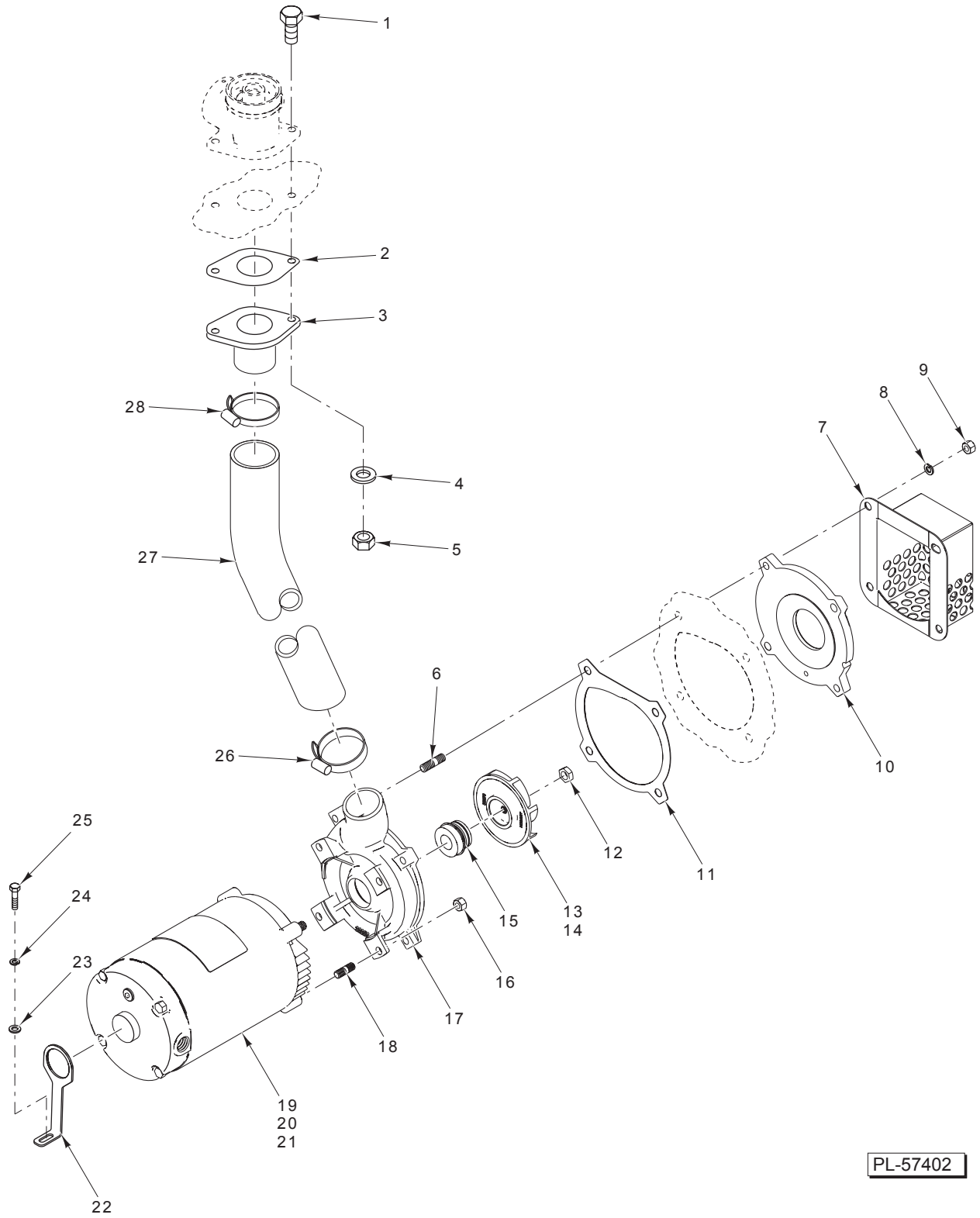

PL-57402

MOTOR AND PUMP

MOTOR AND PUMP

ILLUS.	PART NO.	NAME OF PART	AMT.
PL-57402			
1	SC-041-14	Cap Screw ⁵ / ₁₆ -18 x 1 ¹ / ₈ Hex Hd.	2
2	00-893103	Gasket – Adapter	1
3	00-893102-00001	Adapter – Pump to Manifold	1
4	WS-017-01	Washer	2
5	NS-036-19	Stop Nut ⁵ / ₁₆ -18 Hex	2
6	00-893039-00006	Stud ³ / ₈ -16 x 1 ⁵ / ₈	4
7	00-893063	Screen – Pump	1
8	WL-006-28	Lockwasher ³ / ₈ Helical	4
9	00-893039-00012	Nut ³ / ₈ -16 Hex	4
10	00-893039-00005	Face – Pump Inside	1
11	00-893039-00004	Gasket – Pump to Tank	1
12	00-893039-00003	Jam Nut ⁷ / ₁₆ -20 Hex	1
13	00-893039-00002	Impeller (60 Hz.)	1
14	00-893039-00011	Impeller (50 Hz.)	1
15	00-274227-00006	Seal – Shaft	1
16	00-893039-00012	Nut ³ / ₈ -16 Hex	4
17	00-893039-00001	Involute	1
18	00-893039-00007	Stud ³ / ₈ -16 x 1 ¹ / ₈	4
19	00-893039-00008	Motor (208-240/480 V., 60 Hz., 3 Ph.)	1
20	00-893039-00009	Motor (208-240 V., 60 Hz., 1 Ph.)	1
21	00-893039-00010	Motor (240/380 V., 50 Hz., 3 Ph.)	1
22	00-893035	Brace – Pump	1
23	WS-017-01	Washer	1
24	WL-006-23	Lockwasher ⁵ / ₁₆ Helical	1
25	SC-041-11	Cap Screw ⁵ / ₁₆ -18 x ³ / ₄ Hex Hd.	1
26	00-542337	Clamp – Hose	1
27	00-893024	Hose – Discharge	1
28	00-542337	Clamp – Hose	1

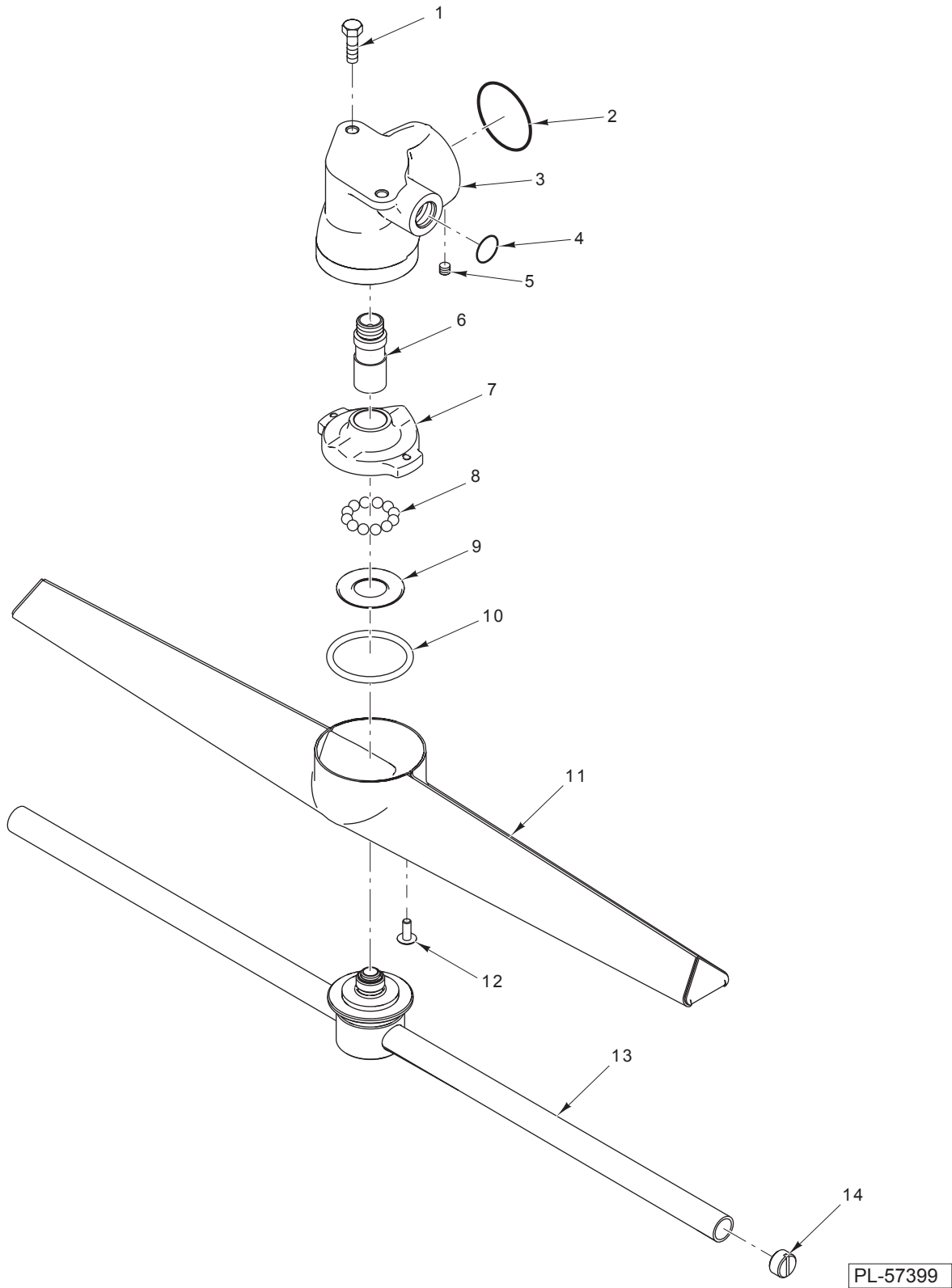

UPPER WASH ARM

UPPER WASH ARM

ILLUS.	PART NO.	NAME OF PART	AMT.
PL-57399			
1	SC-125-20	Cap Screw ⁵ / ₁₆ -18 x ³ / ₈ Hex Hd.	2
2	00-067500-00110	O-Ring	1
3	00-893031	Manifold – Wash (Upper)	1
4	00-067500-00117	O-Ring	1
5	SC-055-01	Set Screw 10-24 x ¹ / ₄ Hex Hdls., Cup Pt.	1
6	00-893052	Shaft – Rinse Arm	1
7	00-893033	Hub – Wash Arm	1
8	BA-002-40	Ball	13
9	00-286947	Retainer – Ball	1
10	00-067500-00019	O-Ring	1
11	00-893007	Arm – Wash	1
12	SC-066-06	Mach. Screw 10-24 x ¹ / ₂ Phil. Truss Hd.	2
13	00-893093-00001	Arm – Rinse (Incls. Item 14)	1
14	00-893093-00002	Plug – Rinse Arm	2
	00-893008	Wash Arm Assy. (Incls. Items 7 thru 12)	1

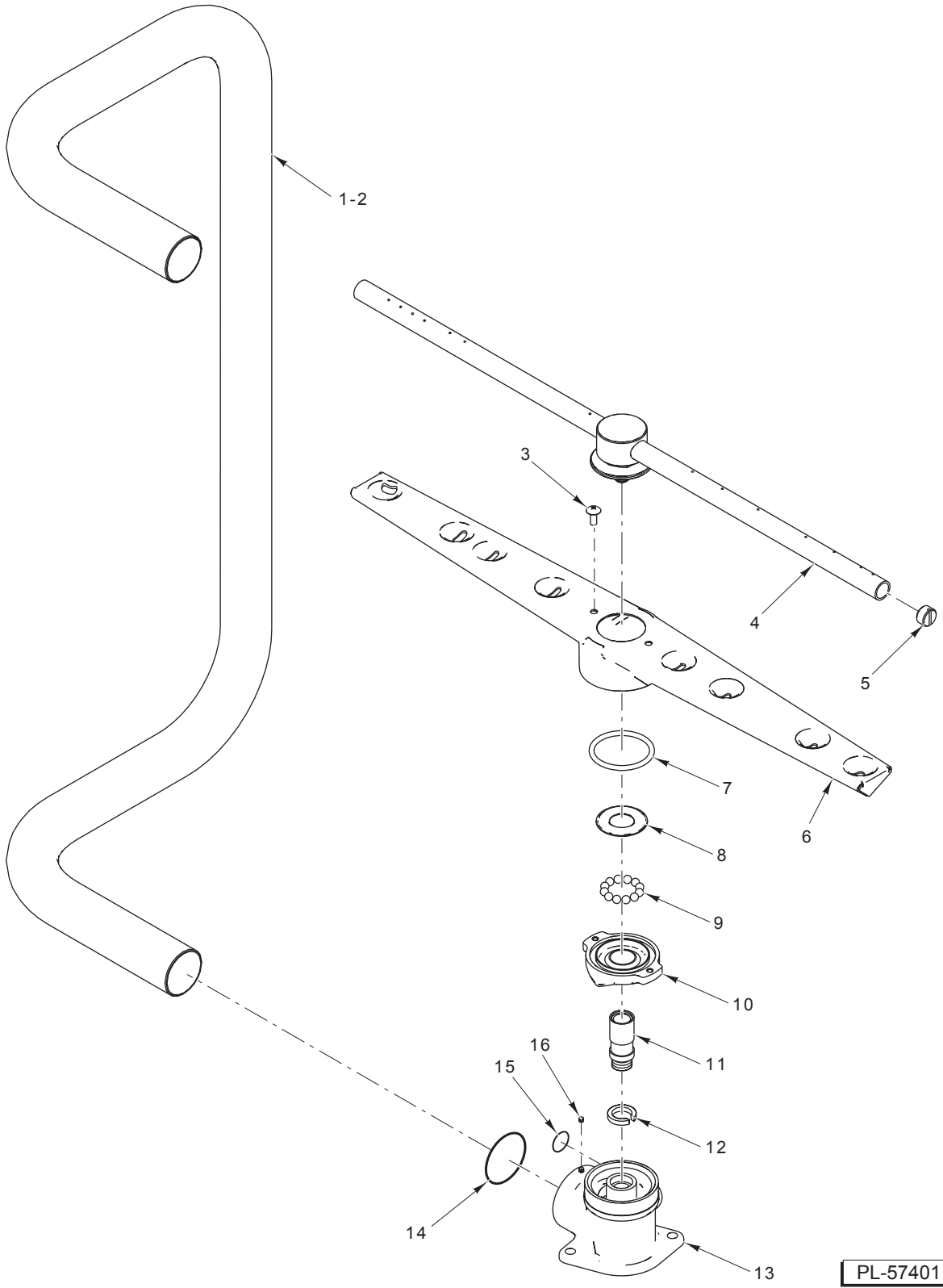

PL-57401

LOWER WASH ARM

LOWER WASH ARM

ILLUS. PL-57401	PART NO.	NAME OF PART	AMT.
1	00-893032	Tube – Wash (AM15).....	1
2	00-893032-00002	Tube – Wash (AM15T & AM15F).....	1
3	SC-066-06	Mach. Screw 10-24 x 1/2 Phil. Truss Hd.	2
4	00-893093-00001	Arm – Rinse (Incls. Item 5).....	1
5	00-893093-00002	Plug – Rinse Arm.....	2
6	00-893007	Arm – Wash.....	1
7	00-067500-00019	O-Ring.....	1
8	00-286947	Retainer – Ball.....	1
9	BA-002-40	Ball.....	13
10	00-893033	Hub – Wash Arm.....	1
11	00-893052	Shaft – Rinse Arm.....	1
12	00-893044	Bushing – Wash Arm.....	1
13	00-893030	Manifold – Wash (Lower).....	1
14	00-067500-00110	O-Ring.....	1
15	00-067500-00117	O-Ring.....	1
16	SC-055-01	Set Screw 10-24 x 1/4 Hex Hdls., Cup Pt.....	2
	00-893008	Wash Arm Assy. (Incls. Items 3 & 6 thru 10).....	1

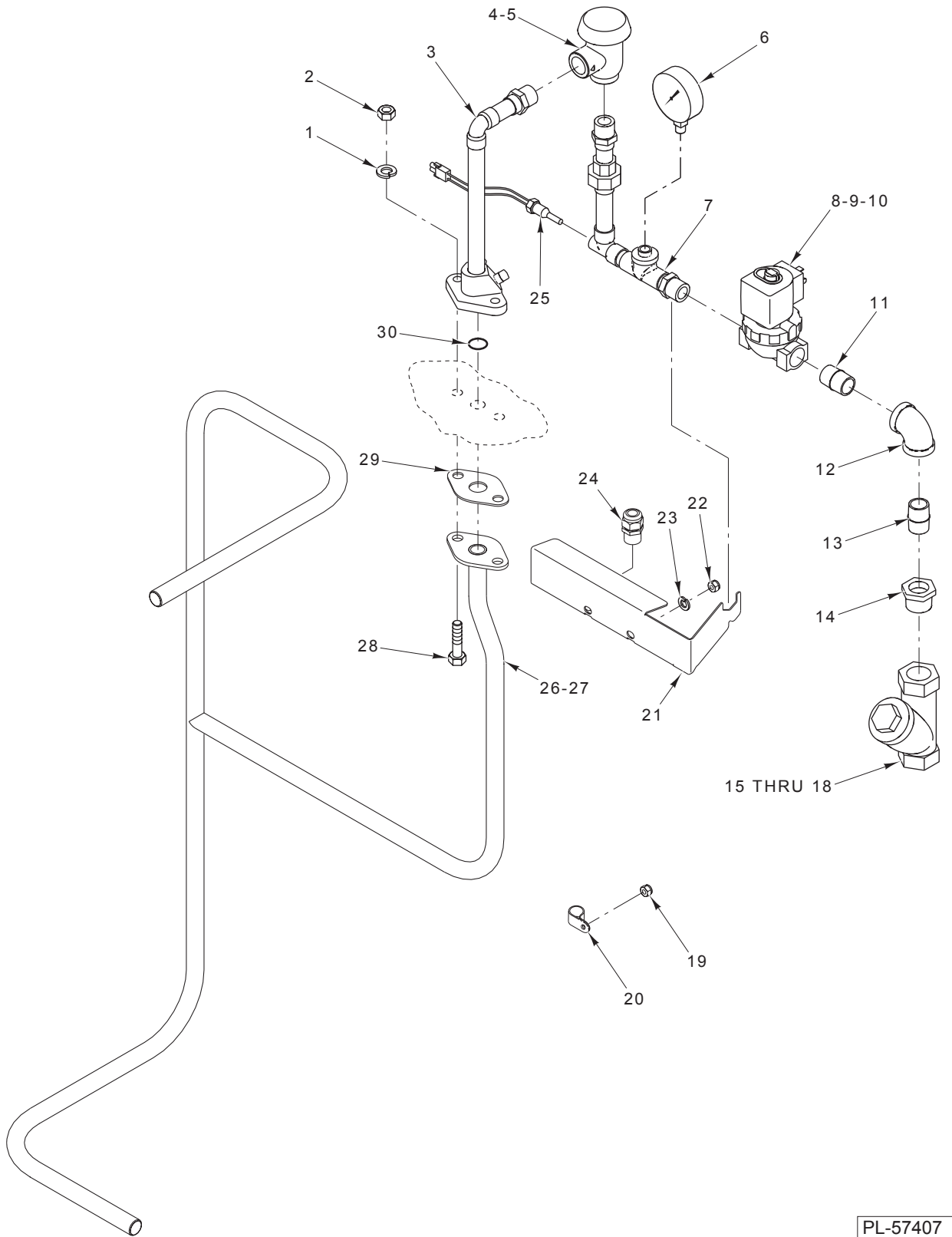

PL-57407

INSIDE PIPING AND OUTSIDE RINSE PIPING (W/O BOOSTER)

INSIDE PIPING AND OUTSIDE RINSE PIPING (W/O BOOSTER)

ILLUS. PL-57407	PART NO.	NAME OF PART	AMT.
1	WL-006-23	Lockwasher ⁵ / ₁₆ Helical	2
2	NS-036-19	Stop Nut ⁵ / ₁₆ -18 Hex	2
3	00-893054	Piping – Fill	1
4	00-292909	Breaker – Vacuum	1
5	00-292910	Kit – Vacuum Breaker	1
6	00-328247	Gauge – Water Pressure	1
7	00-893058	Fill Piping Assy.	1
8	00-893100-00001	Valve – Solenoid (¹ / ₂ In.) (120 V.)	1
9	00-892132	Coil – Solenoid Valve (120 V.)	1
10	00-893101	Kit – Solenoid Valve	1
11	FP-040-44	Pipe ¹ / ₂ x 1 ³ / ₈ TBE (Brass)	1
12	FP-015-16	Elbow – Pipe ¹ / ₂ x 90 Deg. (Brass)	1
13	FP-040-42	Pipe ¹ / ₂ x 1 ¹ / ₄ TBE (Brass)	1
14	FP-027-22	Bushing – Pipe ³ / ₄ to ¹ / ₂ (Brass)	1
15	00-186922	Strainer – Line (³ / ₄ In.) (Brass)	1
16	00-186923	Plug – Branch	1
17	00-186925	Screen – Line Strainer	1
18	00-186924	Gasket – Branch Plug	1
19	NS-047-94	Lock Nut ³ / ₁₆ Washer Type	1
20	00-294677-00004	Clamp – Wire	1
21	00-893053	Bracket – Fill Piping	1
22	NS-015-11	Nut ⁵ / ₁₆ -18 Hex	2
23	WL-006-23	Lockwasher ⁵ / ₁₆ Helical	2
24	FE-022-84	Strain Relief	2
25	00-328994	Probe Assy. – Rinse	1
26	00-893038-00001	Inside Rinse Piping Assy. (AM15)	1
27	00-893038-00004	Inside Rinse Piping Assy. (AM15T & AM15F)	1
28	SC-041-12	Cap Screw ⁵ / ₁₆ -18 x ⁷ / ₈ Hex Hd.	2
29	00-276407	Gasket	1
30	00-067500-00012	O-Ring	1

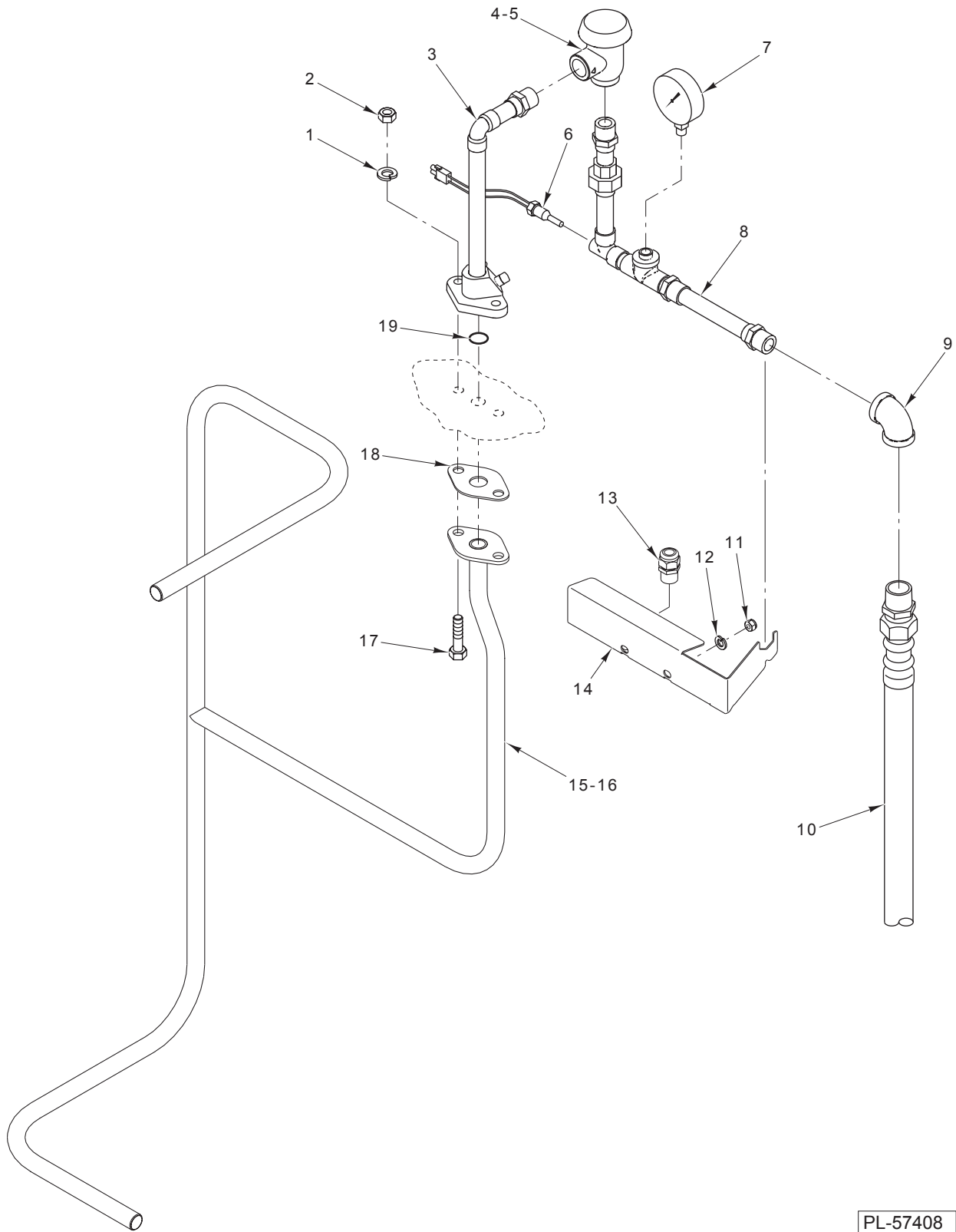

PL-57408

INSIDE PIPING AND OUTSIDE RINSE PIPING (W/BOOSTER)

INSIDE PIPING AND OUTSIDE RINSE PIPING (W/BOOSTER)

ILLUS. PL-57408	PART NO.	NAME OF PART	AMT.
1	WL-006-23	Lockwasher ⁵ / ₁₆ Helical	2
2	NS-036-19	Stop Nut ⁵ / ₁₆ -18 Hex	2
3	00-893054	Piping – Fill	1
4	00-292909	Breaker – Vacuum	1
5	00-292910	Kit – Vacuum Breaker	1
6	00-328994	Probe Assy. – Rinse	1
7	00-328247	Gauge – Water Pressure	1
8	00-893059	Fill Piping Assy.	1
9	FP-015-16	Elbow – Pipe ¹ / ₂ x 90 Deg. (Brass)	1
10	00-893444-00002	Hose – Water ¹ / ₂ x 84 In. Braided (SST)	1
11	NS-015-11	Nut ⁵ / ₁₆ -18 Hex	2
12	WL-006-23	Lockwasher ⁵ / ₁₆ Helical	2
13	FE-022-84	Strain Relief	1
14	00-893053	Bracket – Fill Piping	1
15	00-893038-00001	Inside Rinse Piping Assy. (AM15)	1
16	00-893038-00004	Inside Rinse Piping Assy. (AM15T & AM15F)	1
17	SC-041-12	Cap Screw ⁵ / ₁₆ -18 x ⁷ / ₈ Hex Hd.	2
18	00-276407	Gasket	1
19	00-067500-00012	O-Ring	1

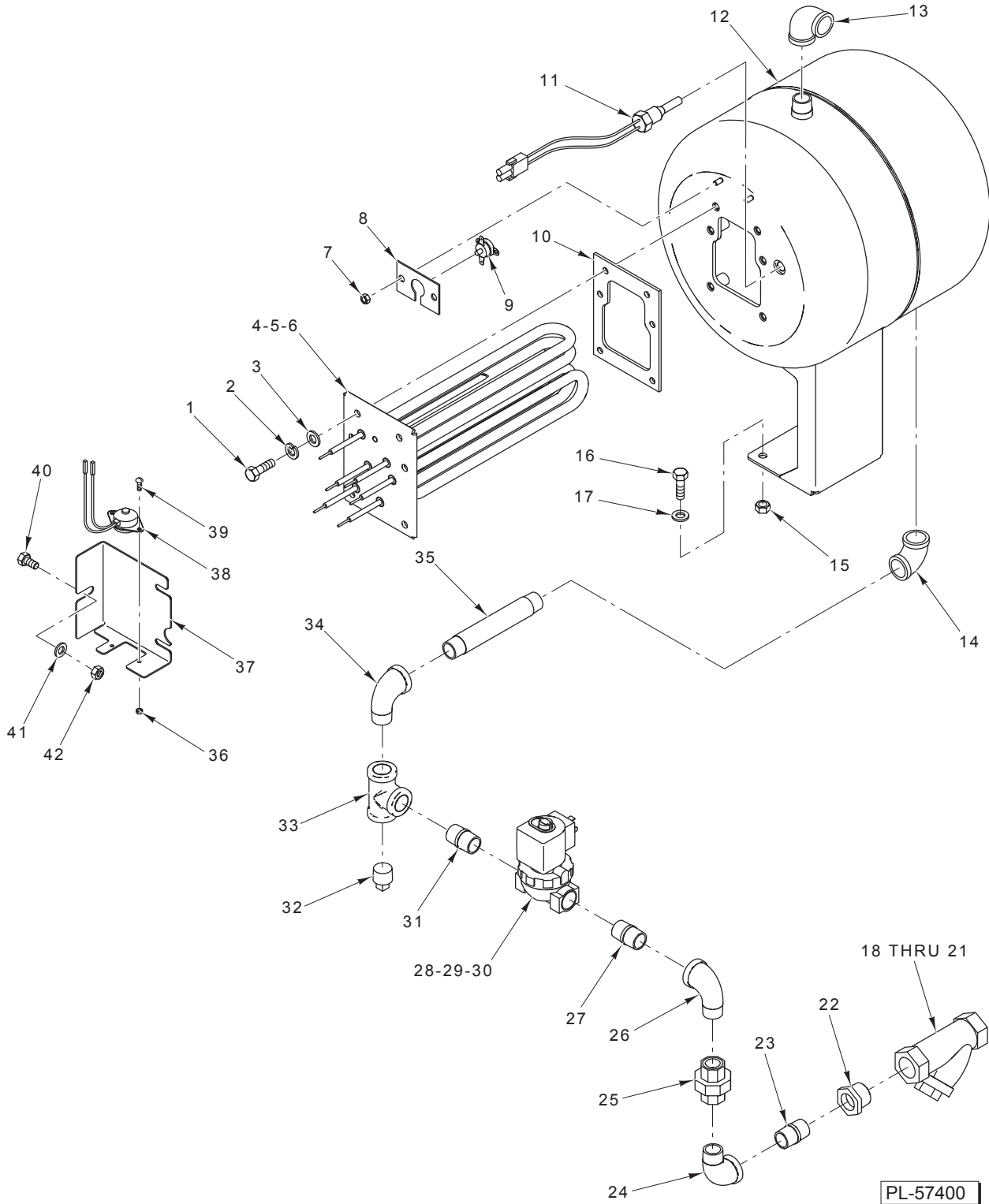

ELECTRIC BOOSTER TANK

ELECTRIC BOOSTER TANK

ILLUS. PL-57400	PART NO.	NAME OF PART	AMT.
1	SC-041-01	Cap Screw 1/4-20 x 3/4 Hex Hd. (SST)	6
2	WL-006-17	Lockwasher 1/4 Medium	6
3	WS-017-06	Washer	6
4	00-749554-00002	Heater (13 kW) (208/240 V.)	1
5	00-749554-00003	Heater (13 kW) (480 V.)	1
6	00-749554-00004	Heater (13 kW) (380 V.)	1
7	NS-031-16	Stop Nut 10-24 Hex	2
8	00-475967	Bracket – High Limit	1
9	00-294615-00001	Control – Temperature	1
10	00-749555	Gasket (13 kW) (Electric Heater)	1
11	00-328994	Probe Assy. – Rinse	1
12	00-893047	Tank – Weldment	1
13	FP-015-16	Elbow – Pipe 1/2 x 90 Deg. (Brass)	1
14	FP-015-16	Elbow – Pipe 1/2 x 90 Deg. (Brass)	1
15	NS-036-19	Stop Nut 5/16-18 Hex	3
16	SC-041-11	Cap Screw 5/16-18 x 3/4 Hex Hd. (SST)	3
17	WS-017-01	Washer	3
18	00-186922	Strainer – Line (3/4 In.) (Brass)	1
19	00-186923	Plug – Branch	1
20	00-186925	Screen – Line Strainer	1
21	00-186924	Gasket – Branch Plug	1
22	FP-027-22	Bushing – Pipe 3/4 to 1/2	1
23	FP-040-43	Pipe 1/2 x 1 1/4 TBE (Brass)	1
24	FP-015-17	Elbow – Pipe 1/2 x 90 Deg. (Brass)	1
25	FP-022-12	Pipe – Union	1
26	FP-015-17	Elbow – Pipe 1/2 x 90 Deg. (Brass)	1
27	FP-040-43	Pipe 1/2 x 1 1/4 TBE (Brass)	1
28	00-893100-00001	Valve – Solenoid (1/2 In.) (120 V.)	1
29	00-893101	Kit – Water Valve (1/2 In.)	AR
30	00-892132	Coil – Solenoid Valve (120 V.)	1
31	FP-040-43	Pipe 1/2 x 1 1/4 TBE (Brass)	1
32	FP-028-15	Pipe Plug 1/2 Sq. Hd.	1
33	FP-019-21	Tee – Pipe 1/2 x 1/2 x 1/2 (Brass)	1
34	FP-015-17	Elbow – Pipe 1/2 x 90 Deg. (Brass)	1
35	FP-040-95	Pipe 1/2 x 7 TBE (Brass)	1
36	NS-031-50	Stop Nut 6-32 Hex (SST)	2
37	00-893082	Bracket – High Limit Protector	1
38	00-271123	Protector – High Limit	1
39	SC-021-08	Mach. Screw 6-32 x 3/8 Rd. Hd. (SST)	2
40	SC-041-11	Cap Screw 5/16-18 x 3/4 Hex Hd. (SST)	1
41	WS-017-01	Washer	1
42	NS-036-19	Stop Nut 5/16-18 Hex	1
	00-519504	Lube	AR

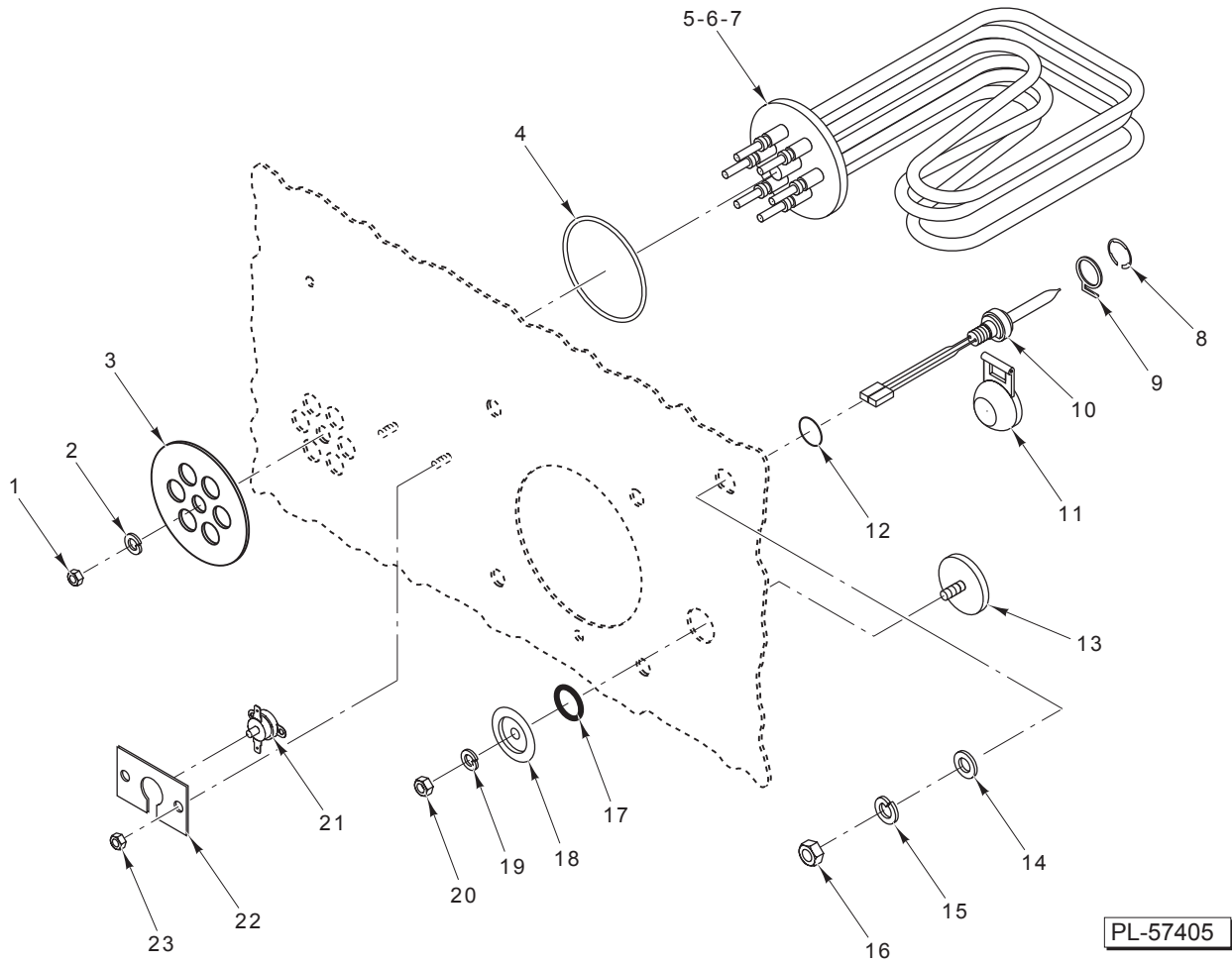

LOW WATER PROTECTION AND ELECTRIC HEAT

LOW WATER PROTECTION AND ELECTRIC HEAT

ILLUS.	PART NO.	NAME OF PART	AMT.
PL-57405			
1	NS-014-15	Nut ³ / ₈ -16 Hex (Brass).....	1
2	WL-006-27	Lockwasher ³ / ₈ Helical	1
3	00-749798	Plate – Electric Heat	1
4	00-067500-00034	O-Ring	1
5	00-893120-00001	Element – Heater (5 kW) (200-240 V., 50/60 Hz., 1 & 3 Ph.).....	1
6	00-893120-00002	Element – Heater (5 kW) (480 V., 60 Hz., 3 Ph.)	1
7	00-893120-00003	Element – Heater (5 kW) (380-415 V., 50 Hz., 3 Ph.)	1
8	RR-010-13	Retaining Ring	1
9	00-112467	Retainer – Float	1
10	00-271621	Probe & Switch Assy. (4 Wire) (Temperatures & Water Level)	1
11	00-122674	Float Assy.	1
12	00-067500-00072	O-Ring	1
13	00-119244	Cap & Stud Assy.	1
14	WS-010-40	Washer	1
15	WL-014-31	Lockwasher ¹ / ₂ External Shakeproof (SST).....	1
16	NS-018-28	Jam Nut ¹ / ₂ -20 Hex	1
17	00-067500-00031	O-Ring	1
18	00-119254	Retainer – Cap	1
19	WL-006-17	Lockwasher ¹ / ₄ Helical	1
20	NS-015-01	Nut ¹ / ₄ -20 Hex	1
21	00-294615-00001	Control – Temperature	1
22	00-475967	Bracket – High Limit	1
23	NS-031-16	Stop Nut 10-24 Hex	2
	00-186091	Probe & Float Assy. (Incls. Items 8 thru 11).....	1
	00-519504	Lube	AR

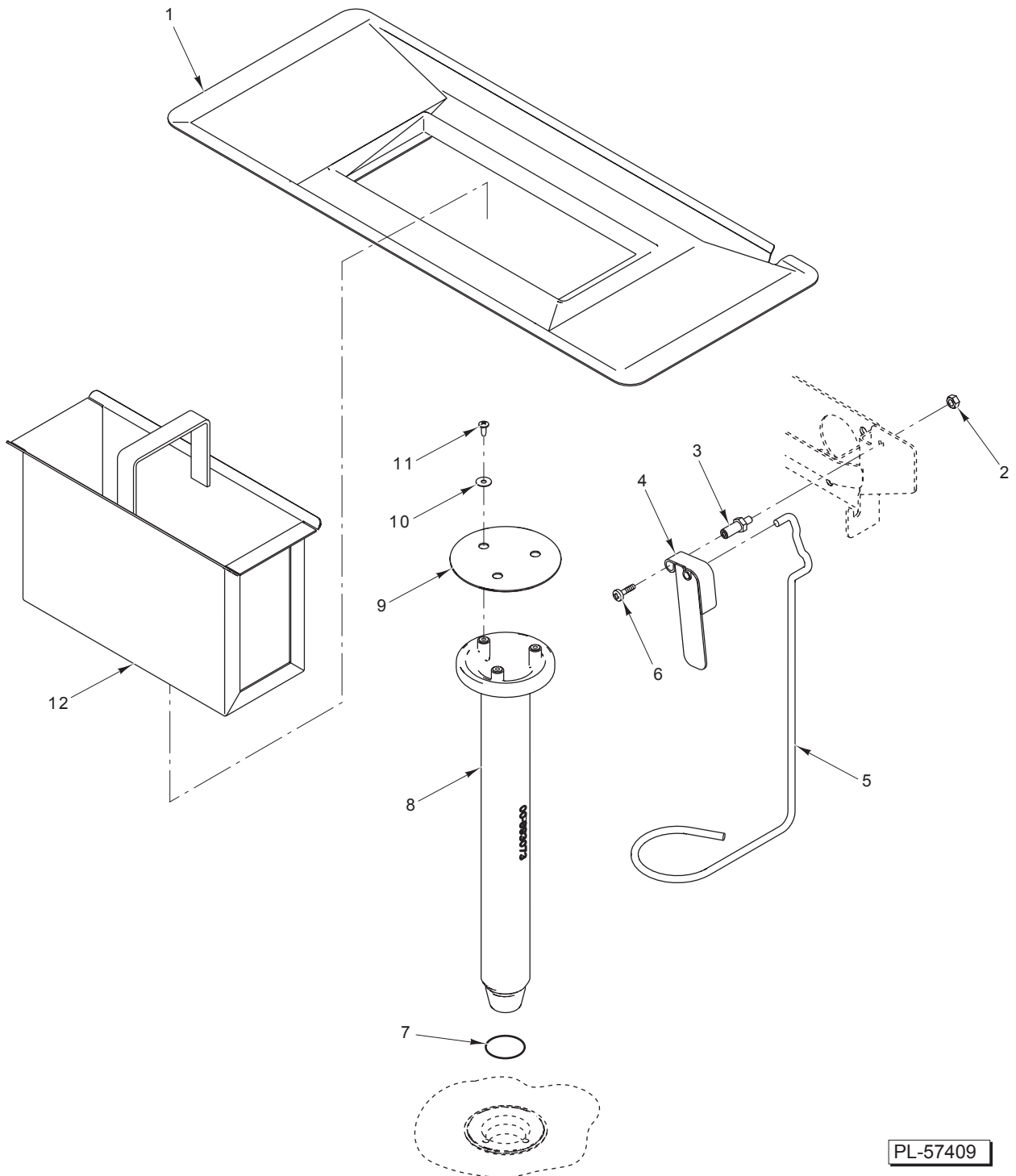

PL-57409

DRAIN UNIT

DRAIN UNIT

ILLUS.	PART NO.	NAME OF PART	AMT.
PL-57409			
1	00-893045	Strainer Pan	1
2	NS-047-82	Stop Nut 1/4-20 Hex (SST)	1
3	00-119116	Axle – Drain Lever	1
4	00-893091	Drain Lever Assy.	1
5	00-893095	Drain – Lift	1
6	SC-066-06	Mach. Screw 10-24 x 1/2 Phil. Truss Hd.	
7	00-067500-00120	O-Ring	1
8	00-893071	Drain Tube Assy. (Incls. Items 9, 10, & 11)	1
9	00-893072	Cover – Standpipe	1
10	WS-019-33	Washer	3
11	SD-038-84	Self-Tapping Screw 10-24 x 1/2 Phil. Truss Hd., Type F (SST)	3
12	00-118999	Strainer Basket Assy.	1

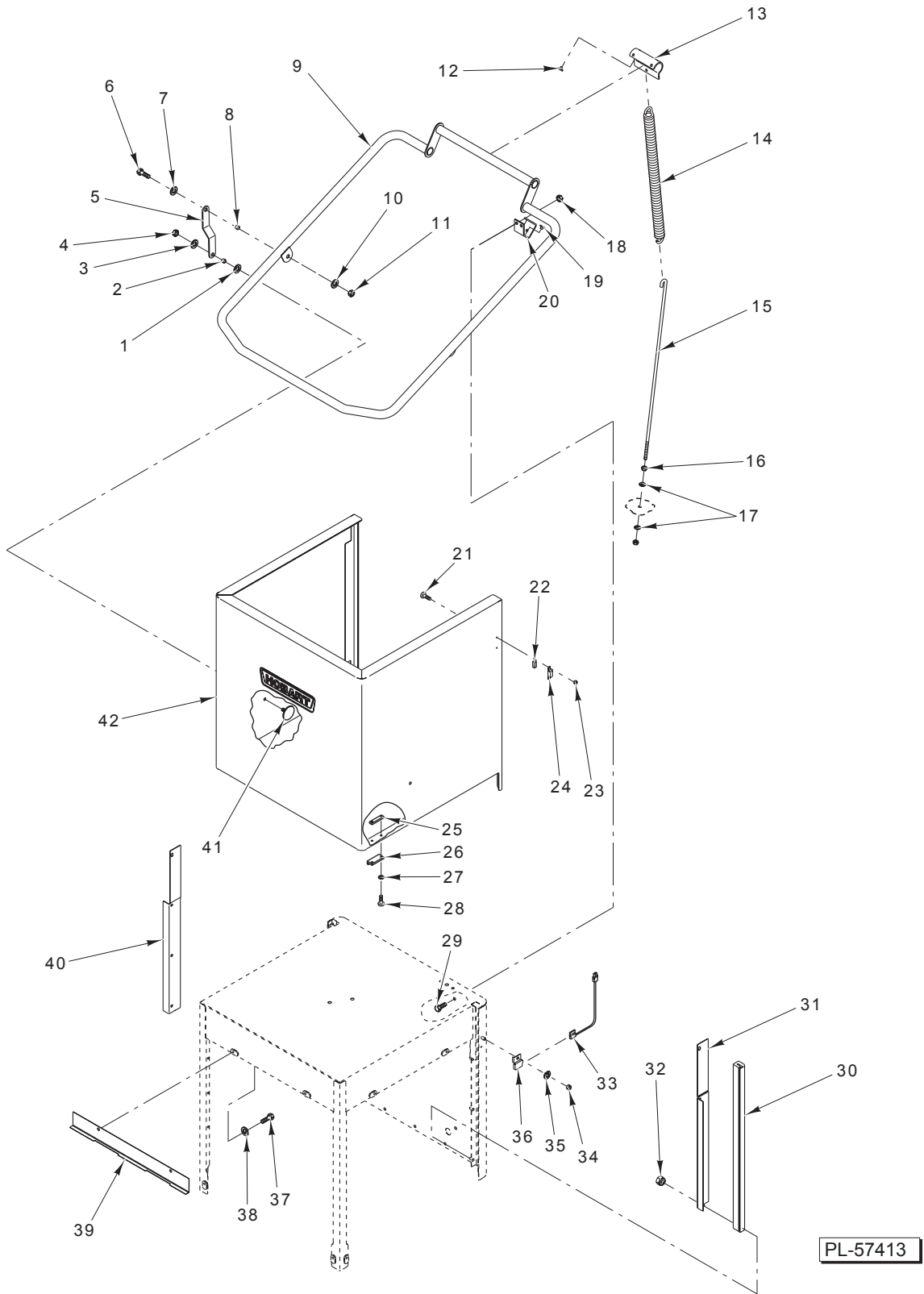

DOOR ASSEMBLY (AM15)

DOOR ASSEMBLY (AM15)

ILLUS.	PART NO.	NAME OF PART	AMT.
PL-57413			
1	WS-017-01	Washer	2
2	00-893014-00002	Spacer – Door Link (Lower)	2
3	WS-017-01	Washer	2
4	NS-036-19	Stop Nut ⁵ / ₁₆ -18 Hex	2
5	00-893252	Link – Door Handle	2
6	SC-041-12	Cap Screw ⁵ / ₁₆ -18 x ⁷ / ₈ Hex Hd.	2
7	WS-017-01	Washer	2
8	00-893014-00001	Spacer – Door Link (Upper)	2
9	00-893051	Handle – Weldment	1
10	WS-017-01	Washer	2
11	NS-036-19	Stop Nut ⁵ / ₁₆ -18 Hex	2
12	00-119055	Button – Bearing	4
13	00-893011	Hanger – Counterbalance (Spring)	1
14	00-893012	Spring – Extension (Door)	1
15	00-893013	Hook – Spring	1
16	NS-015-11	Nut ⁵ / ₁₆ -18 Hex	3
17	WS-017-01	Washer	2
18	NS-036-19	Stop Nut ⁵ / ₁₆ -18 Hex	4
19	00-119055	Button – Bearing	4
20	00-893224	Support – Handle	2
21	SC-066-01	Mach. Screw 6-32 x ¹ / ₄ Phil Truss Hd.	2
22	00-111941	Magnet	1
23	NS-031-50	Stop Nut 6-32 Hex	2
24	00-893111	Magnet – Mount	1
25	00-893826	Door Guide Mount	2
26	00-893801	Spacer – Door Guide	2
27	WS-023-01	Washer	4
28	SC-066-02	Mach. Screw 6-32 x ³ / ₈ Phil. Truss Hd.	4
29	SC-041-09	Cap Screw ⁵ / ₁₆ -18 x ¹ / ₂ Hex Hd.	4
30	00-893193-00001	Guide – Door	2
31	00-893201-00002	Cover – Door Guide (RH)	1
32	NS-047-82	Stop Nut ¹ / ₄ -20 Hex	4
33	00-473109-00004	Switch Assy. – Door	1
34	NS-015-11	Nut ⁵ / ₁₆ -18 Hex	1
35	WL-006-23	Lockwasher ⁵ / ₁₆ Helical	1
36	00-893853	Bracket – Reed Switch Mounting	1
37	SC-041-11	Cap Screw ⁵ / ₁₆ -18 x ³ / ₄ Hex Hd.	6
38	WL-006-23	Lockwasher ⁵ / ₁₆ Helical	6
39	00-893015	Stop – Door	3
40	00-893201	Cover – Door Guide (LH)	1
41	00-893226	Stiffener – Door Plate	2
42	00-893202	Door Wrap	1

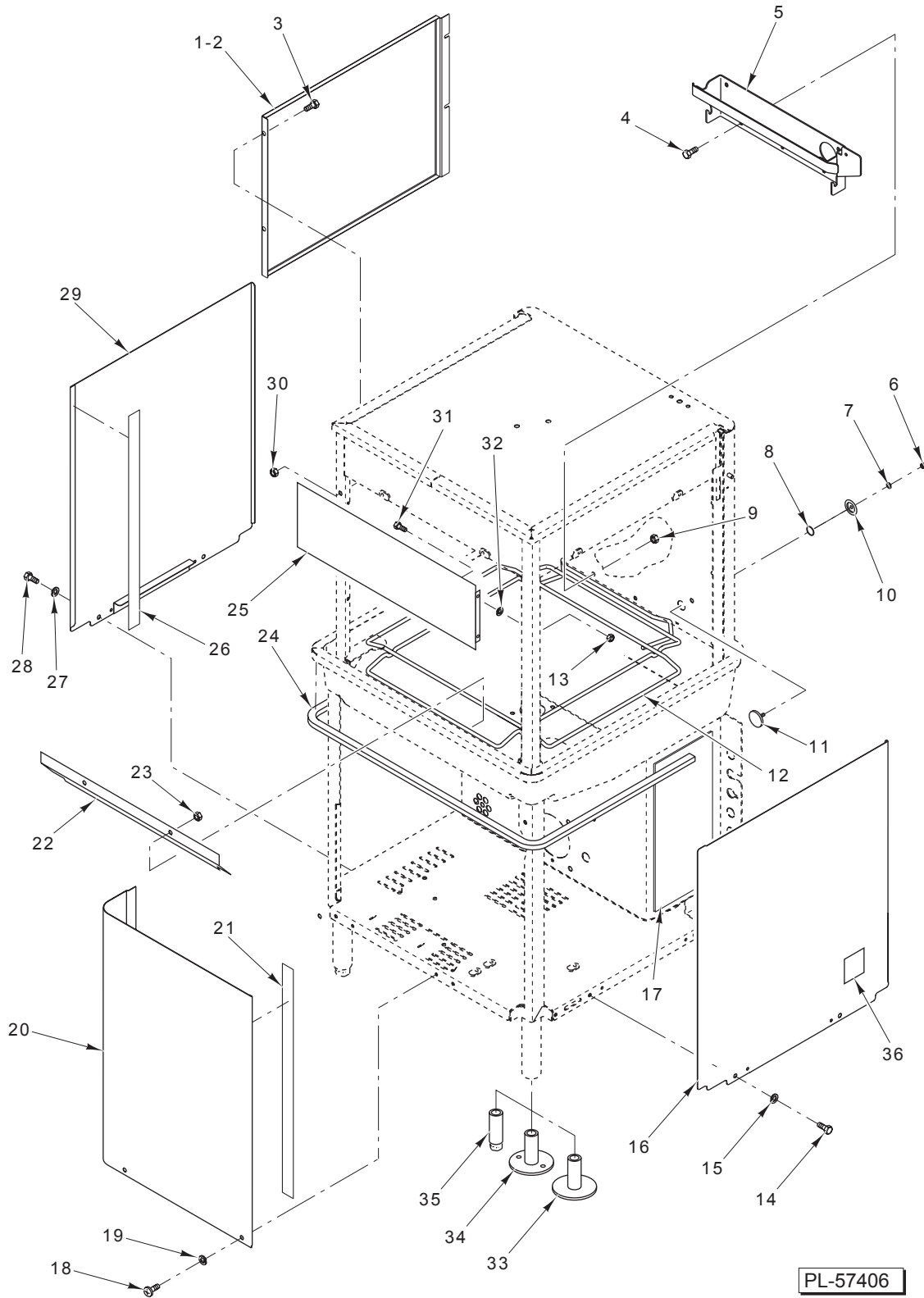

PANELS AND RACK SUPPORT

PANELS AND RACK SUPPORT

ILLUS.	PART NO.	NAME OF PART	AMT.
PL-57406			
1	00-893203	Panel – Splash (AM15).....	1
2	00-893096	Panel – Splash (AM15T & AM15F).....	2
3	SC-059-29	Cap Screw 1/4-20 x 1/2 Hex Socket Hd.	2
4	SC-041-10	Cap Screw 5/16-18 x 1/2 Hex Hd.	5
5	00-893798	Rack – Stop Assy.	1
6	NS-015-01	Nut 1/4-20 Hex 1	1
7	WL-006-17	Lockwasher 1/4 Helical 1	1
8	00-067500-00031	O-Ring 1	1
9	NS-036-19	Stop Nut 5/16-18 Hex 5	5
10	00-119254	Retainer – Cap 1	1
11	00-119244	Cap & Stud Assy. 1	1
12	00-893790-00001	Wireform Assy. 1	1
13	NS-047-82	Stop Nut 1/4-20 Hex 4	4
14	SC-041-50	Cap Screw 1/4-20 x 1/2 Hex Hd. 2	2
15	WL-006-17	Lockwasher 1/4 Helical 2	2
16	00-893042	Panel – Cover (Right Side) 1	1
17	00-918097	Kit – Foam Installation AR	AR
18	SC-125-15	Mach. Screw 1/4-20 x 1/2 Phil. Truss Hd. 2	2
19	WL-006-17	Lockwasher 1/4 Helical 2	2
20	00-893041	Panel – Cover (Front) 1	1
21	00-526454	Tape – Foam AR	AR
22	00-893069	Baffle – Steam 1	1
23	NS-036-19	Stop Nut 5/16-18 Hex 2	2
24	00-893021	Seal – Extrusion AR	AR
25	00-893775	Deflector 1	1
26	00-526454	Tape – Foam AR	AR
27	WL-006-17	Lockwasher 1/4 Helical 2	2
28	SC-041-50	Cap Screw 1/4-20 x 1/2 Hex Hd. 2	2
29	00-893018	Panel – Cover (Left Side) 1	1
30	NS-047-82	Stop Nut 1/4-20 Hex 2	2
31	SC-059-29	Cap Screw 1/4-20 x 1/2 Hex Socket Hd. 4	4
32	WS-017-06	Washer 4	4
33	00-893122-00002	Foot – Flanged (Without Holes)..... 4	4
34	00-893122-00001	Foot – Flanged (With Holes)..... 4	4
35	00-893122-00003	Foot – Standard 4	4
36	00-438131-061-2	Label – Warning (California) 1	1

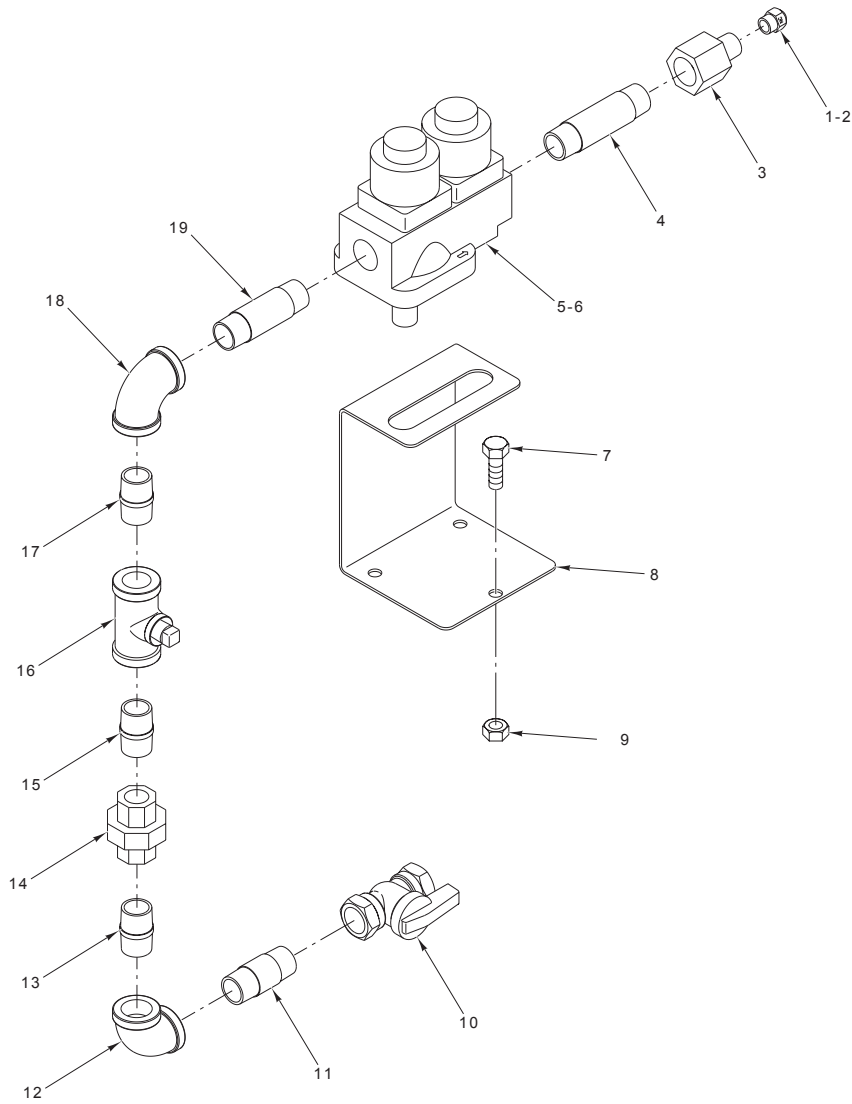

GAS HEAT PIPING

PL-57411

ILLUS.	PART NO.	NAME OF PART	AMT.
	PL-57411		
1	00-893149-00001	Orifice (NAT)	1
2	00-893149-00002	Orifice (LP)	1
3	00-893132	Adapter 1/2 to 7/16-20	1
4	FP-059-10	Pipe 1/2 x 3 TBE	1
5	00-328426-00004	Valve – Regulator (NAT)	1
6	00-328426-00005	Valve – Regulator (LP).....	1
7	SC-041-10	Cap Screw 5/16-18 x 5/8 Hex Hd.	3
8	00-893899	Support – Valve Assy.	1
9	NS-015-11	Nut 5/16-18 Hex	3
10	00-291988-00003	Valve – Gas (Shut Off)	1
11	FP-067-04	Pipe 1/2 x 1 7/8 TBE	1
12	FP-013-15	Elbow Pipe 1/2 x 90 Deg.	1
13	FP-067-04	Pipe 1/2 x 1 7/8 TBE	1
14	FP-022-11	Union – Pipe	1
15	FP-067-04	Pipe 1/2 x 1 7/8 TBE	1
16	FP-084-31	Tee Pipe 1/2 x 1/2 x 1/4	1
17	FP-035-94	Pipe 1/2 x 1 1/2 TBE	1
18	FP-013-15	Elbow Pipe 1/2 x 90 Deg.	1
19	FP-036-97	Pipe 1/2 x 2 3/4 TBE	1
	00-893896-00001	Gas Piping Assy. (NAT) (Incls. Items 1, 3, 4, 5, & 10 thru 19)	1
	00-893896-00002	Gas Piping Assy. (LP) (Incls. Items 2, 3, 4, 6, & 10 thru 19)	1

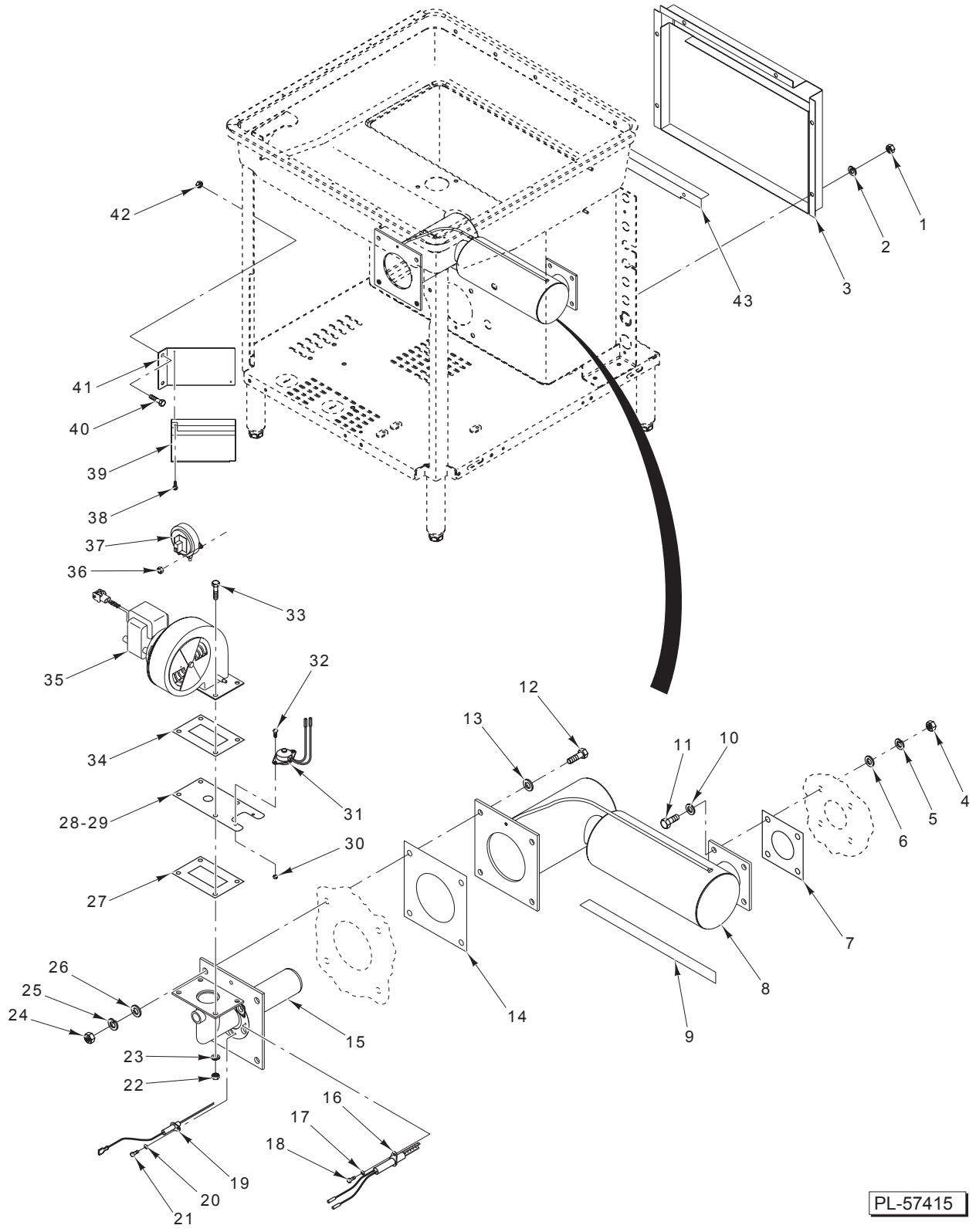

PL-57415

GAS HEAT COMPONENTS

GAS HEAT COMPONENTS

ILLUS.	PART NO.	NAME OF PART	AMT.
PL-57415			
1	NS-031-21	Stop Nut 1/4-20 Hex	6
2	WL-014-10	Lockwasher 1/4 External	6
3	00-893890	Shroud – Exhaust	1
4	NS-015-13	Nut 3/8-16 Hex	4
5	WL-006-28	Lockwasher 3/8 Helical	4
6	WS-028-22	Washer	4
7	00-893892	Gasket – Immersion Tube	1
8	00-893879	Tube – Immersion	1
9	00-893900	Turbulator – Immersion Tube	1
10	WS-028-22	Washer	4
11	SC-041-31	Cap Screw 3/8-16 x 1 1/4 Hex Hd.	4
12	SC-041-31	Cap Screw 3/8-16 x 1 1/4 Hex Hd.	4
13	WS-028-22	Washer	4
14	00-893891	Gasket – Immersion tube	1
15	00-893897	Burner – Infrared	1
16	00-748571-00002	Ignitor (With Terminals).....	1
17	WL-006-02	Lockwasher #8 Helical	1
18	SC-021-13	Mach. Screw 8-32 x 1/4 Slotted Rd. Hd.	1
19	00-748572	Electrode Assy.	1
20	WL-006-02	Lockwasher #8 Helical	1
21	SC-021-13	Mach. Screw 8-32 x 1/4 Slotted Rd. Hd.	1
22	NS-031-21	Stop Nut 1/4-20 Hex	4
23	WL-014-10	Lockwasher 1/4 External	4
24	NS-015-13	Nut 3/8-16 Hex	4
25	WL-006-28	Lockwasher 3/8 Helical	4
26	WS-028-22	Washer	4
27	00-918034	Seal – Blower/Burner.....	1
28	00-893893-00001	Plate – Reducer (NAT).....	1
29	00-893893-00002	Plate – Reducer (LP)	1
30	NS-031-50	Stop Nut 6-32 Hex	2
31	00-271123	Protector – High Limit	1
32	SC-021-08	Mach. Screw 6-32 x 3/8 Slotted Rd. Hd.	2
33	SC-041-05	Cap Screw 1/4-20 x 5/8 Hex Hd.	4
34	00-918034	Seal – Blower/Burner.....	1
35	00-893898	Blower – Gas	1
36	NS-031-21	Stop Nut 1/4-20 Hex	2
37	00-748562-00002	Switch – Air	1
38	SD-038-02	Self-Tapping Screw 6-20 x 5/8 Phil. Pan Hd., Type B	2
39	00-748512	Board – Ignitor (24 VAC).....	1
40	SC-041-10	Cap Screw 5/16-18 x 3/8 Hex Hd.	2
41	00-893895	Bracket – Ignitor Board	1
42	NS-015-11	Nut 5/16-18 Hex	2
43	00-893887	Baffle – Exhaust	3

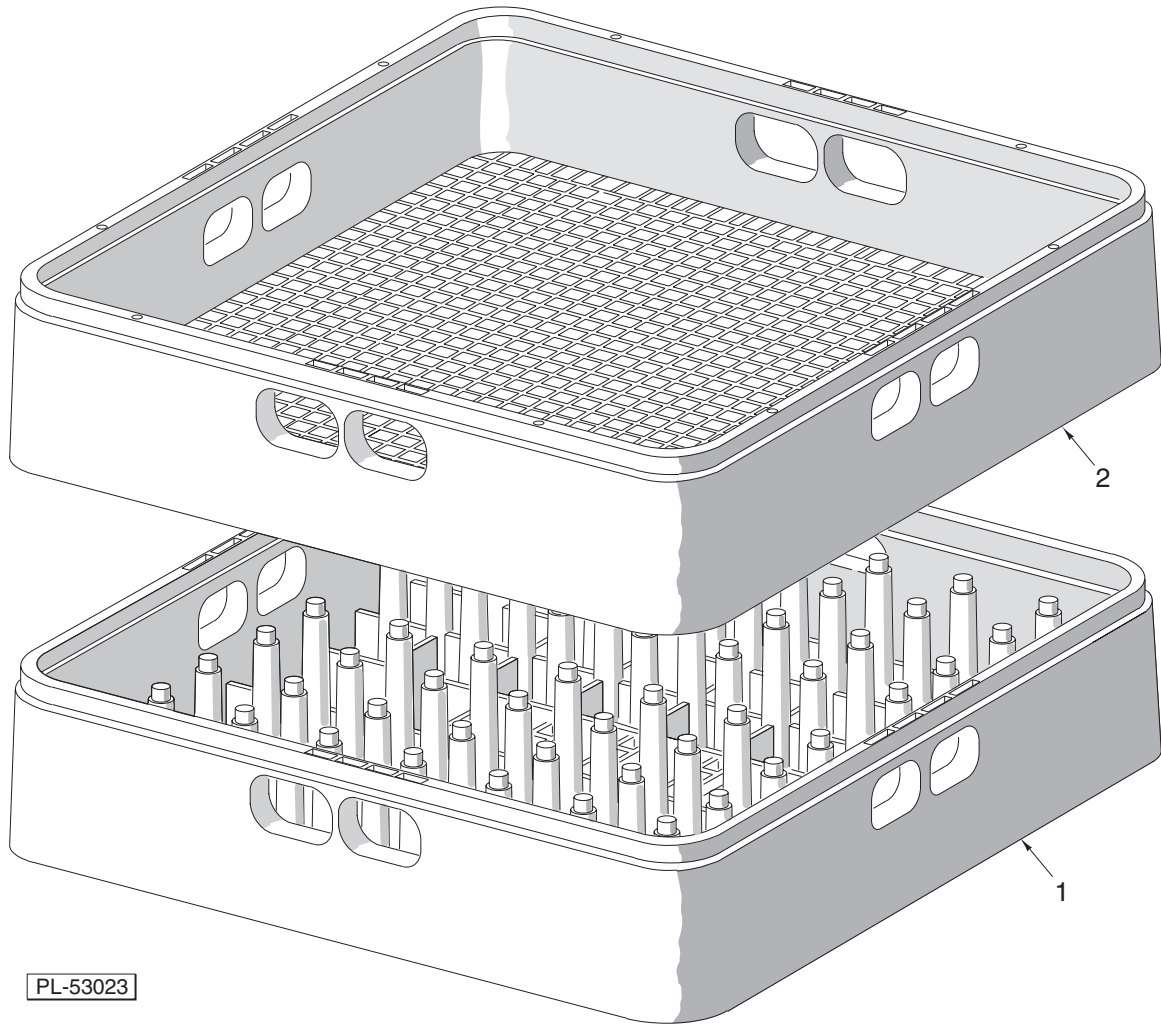

DISH RACKS

ILLUS.	PART NO.	NAME OF PART	AMT.
1	00-315191	Rack – Peg (Packaged).....	1
2	00-315193	Rack – Combination (Packaged).....	1
	00-295288	Peg Type Tray Rack (Packaged).....	1
	00-892671	Rack – Bun Pan.....	1
	00-474800	Rack (6 Pan).....	1